

STATIONS 2 & 4.
STATION No. 6.
STATION No. 7. (TRANSOM).
CENTRE LINES.

EXTEND 2"

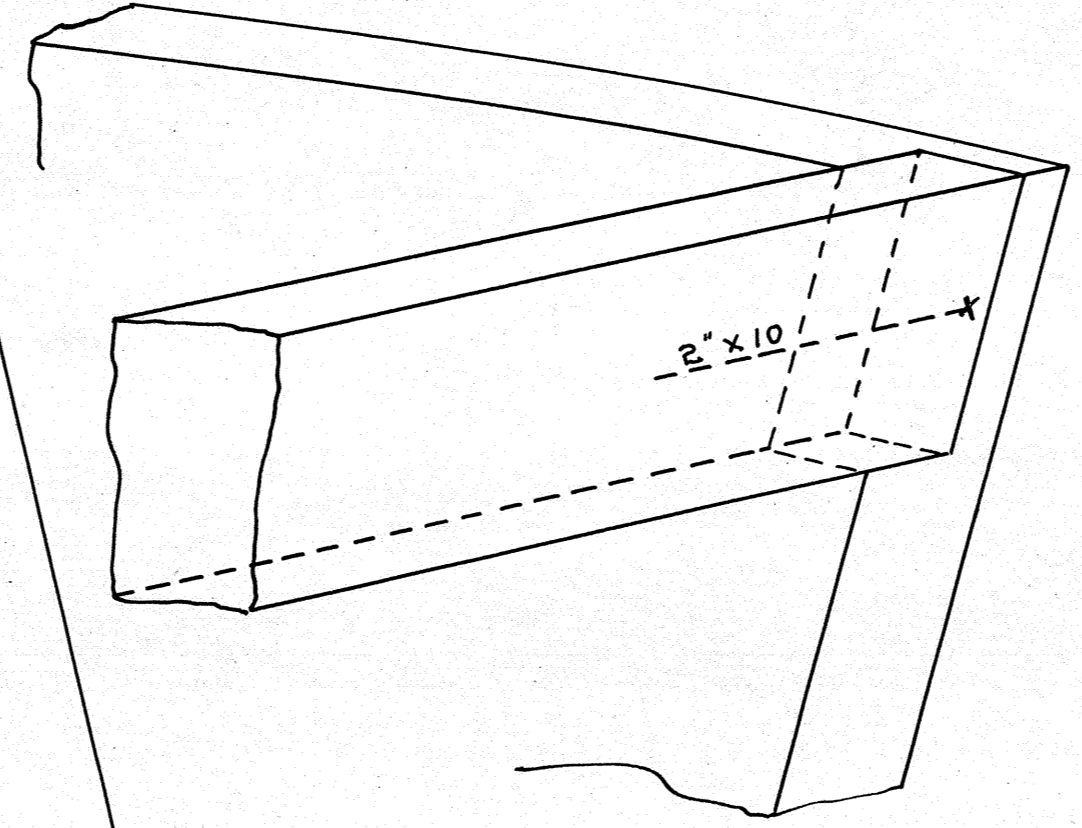
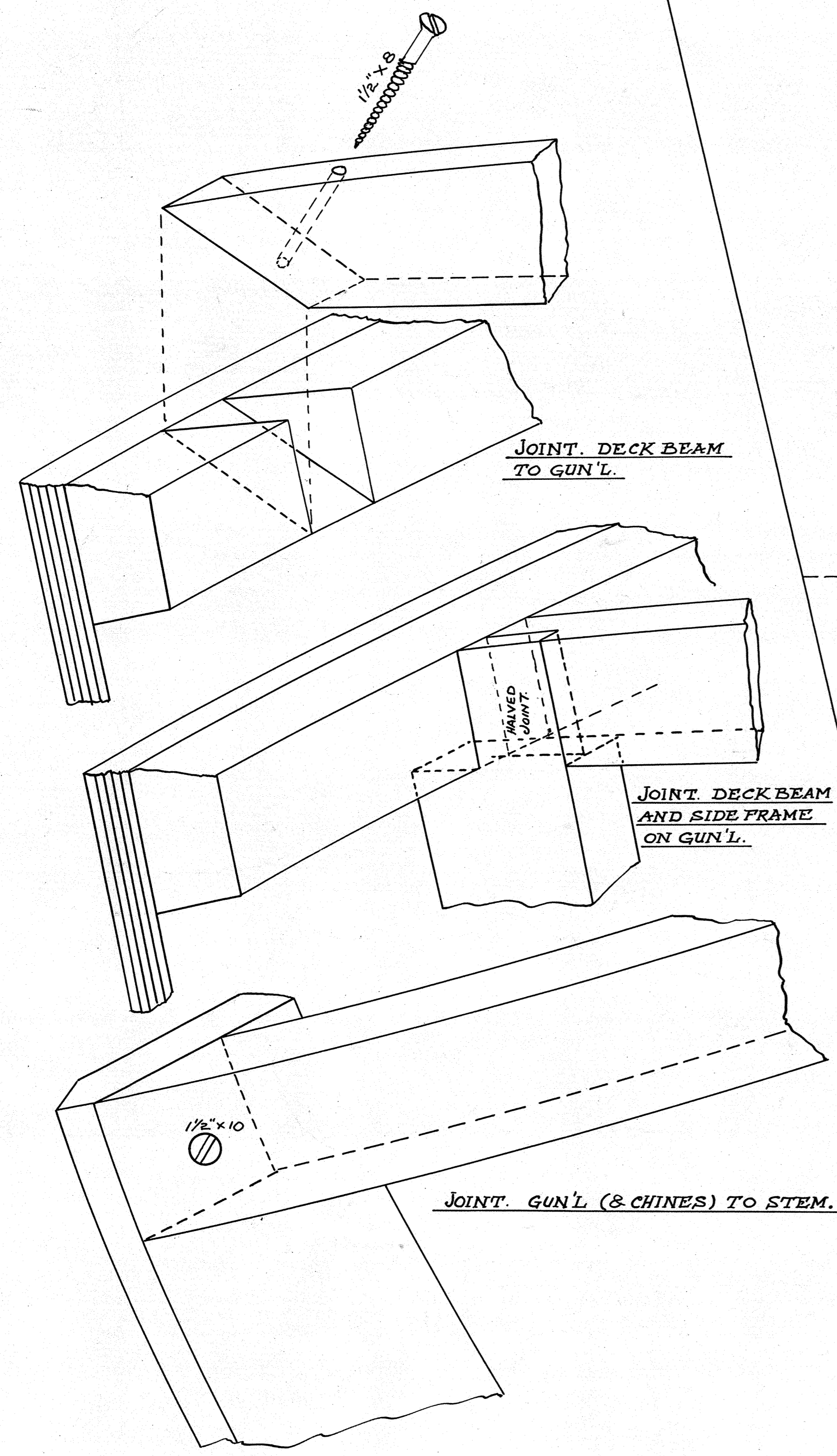

JOINT. GUN'L. (& CHINES) TO TRANSOM.

TOP OF STOCKS FOR FRAME No. 2.

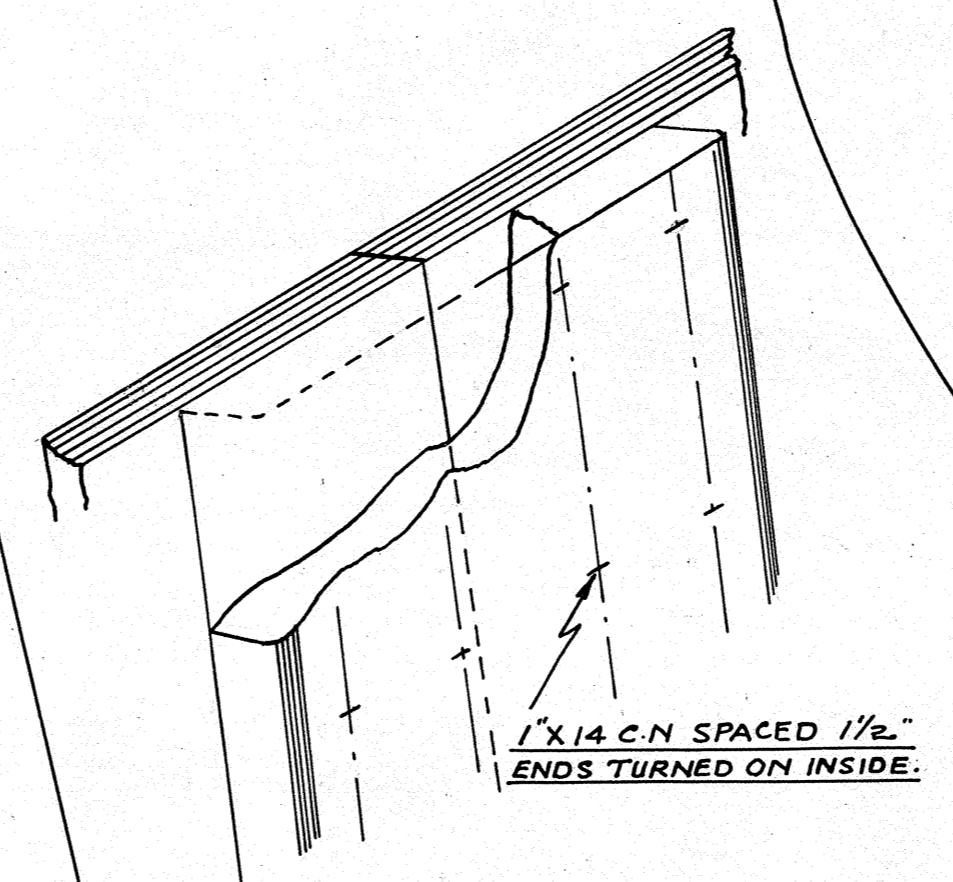

DETAIL OF BUTT STRAP JOINT IN PLANKING. STRAP FROM 5/16" PLY WITH GRAIN LENGTHWAYS. CUT TO TIGHT FIT BETWEEN GUN'L. CHINES, HOG.

CUT TO HALF THICKNESS OF TRANSOM.

CUT TO HALF THICKNESS OF TRANSOM.

TOP OF STOCKS FOR FRAMES 4 & 6 & TRANSOM.

CENTRE LINE FOR STATIONS 4, 6 & 7.

CUT THIS JOINT AS DETAIL ON SHEET NO. 4.

D.W.L. FOR STATIONS 4, 6 & 7.

D.W.L. FOR STATION 2.

CAMBER OF DECK BEAMS & TOP OF TRANSOM.

CENTRE LINE FOR STATION 2.